



US006850125B2

(12) **United States Patent**  
Norman et al.

(10) **Patent No.:** US 6,850,125 B2  
(45) **Date of Patent:** Feb. 1, 2005

(54) **SYSTEMS AND METHODS FOR SELF-CALIBRATION**

(75) Inventors: **Robert D Norman**, Blaine, WA (US);  
**Dominik J. Schmidt**, Palo Alto, CA (US)

(73) Assignee: **Gallitzin Allegheny LLC**, Los Altos, CA (US)

(\* ) Notice: Subject to any disclaimer, the term of this patent is extended or adjusted under 35 U.S.C. 154(b) by 521 days.

(21) Appl. No.: **09/930,828**

(22) Filed: **Aug. 15, 2001**

(65) **Prior Publication Data**

US 2003/0034851 A1 Feb. 20, 2003

(51) **Int. Cl.**<sup>7</sup> ..... **H03B 5/04**

(52) **U.S. Cl.** ..... **331/65; 331/66; 331/68; 331/69**

(58) **Field of Search** ..... **331/57, 65, 66, 331/68-70, 74, 175, 176, 177 R, 179**

(56) **References Cited**

U.S. PATENT DOCUMENTS

5,739,728 A	4/1998	Kim	
5,956,289 A *	9/1999	Norman et al. ....	365/233
6,154,099 A	11/2000	Suzuki et al.	
6,160,755 A	12/2000	Norman et al.	
6,211,744 B1	4/2001	Shin	

\* cited by examiner

*Primary Examiner*—David Mis

(74) *Attorney, Agent, or Firm*—Sterne, Kessler, Goldstein & Fox P.L.L.C.

(57) **ABSTRACT**

A self-calibrating integrated circuit includes a processor having at least one analog function used with the processor; one or more sensors adapted to sense one or more environmental parameters of the at least one analog function; and a solid state memory being configured to store the one or more environmental parameters of the at least one analog function.

**20 Claims, 2 Drawing Sheets**

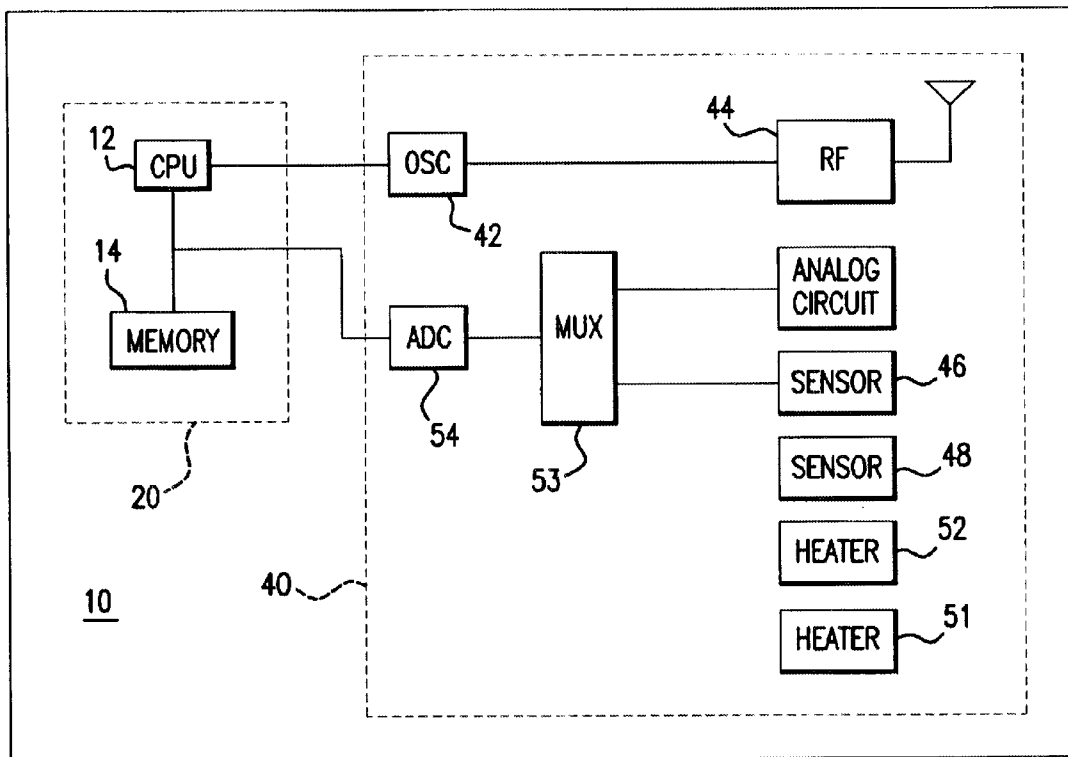

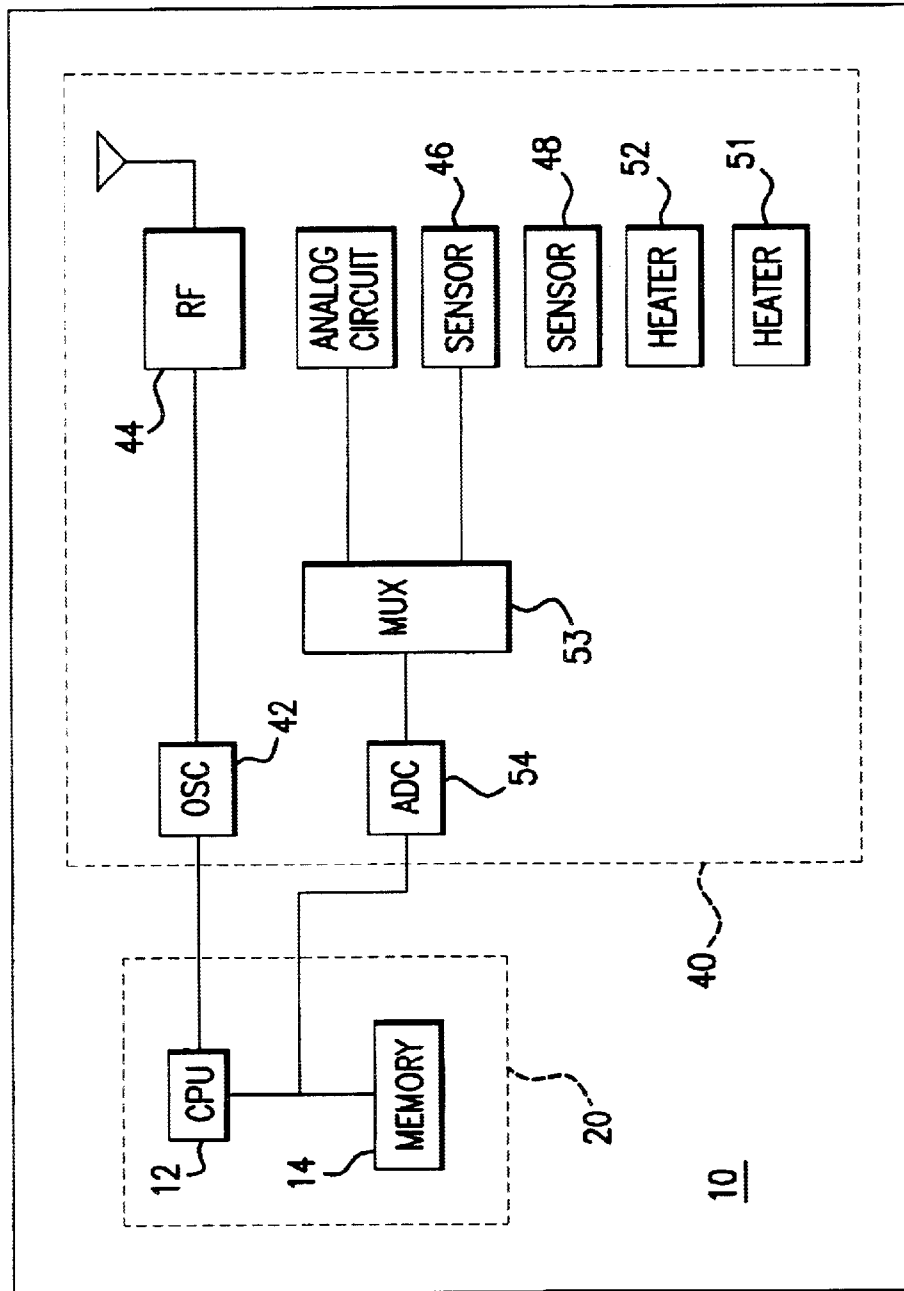

FIG. 1

200

IC is initialized (step 201)
Check for user adjustments (step 202)
Voltage, hot electron and temperature calibration signals are sent to the voltage generators, hot electron sources and heaters (step 203)
Hot electron sensor responses are monitored (step 204)
Hot electron sensor responses are averaged and the averaged result is compared to a predetermined range (step 206)
If the response is out of range, it is corrected in process (step 208)
Temperature sensors are monitored (step 210)
Temperature responses are averaged and the averaged result is compared to a predetermined range (step 216)
If the response is out of range, it is corrected (step 218)
Voltage sensors are monitored (step 220)
Voltage responses are averaged and the averaged result is compared to a predetermined range (step 226)
If the response is out of range, it is corrected (step 228)
Store environmental parameters in memory and repeat (step 240)

FIG.2

## SYSTEMS AND METHODS FOR SELF-CALIBRATION

### BACKGROUND

The present invention relates systems and methods for self-calibrating semiconductor devices.

Today's modern electronic products such as computers and high definition televisions rely on advanced integrated circuits (ICs) that operate at high speed. These products in turn rely on a clock source and clock signal that act as a master timing element for control of hardware.

Traditionally, a master clock source is generated off-chip and provided as an input to the ICs. One method for generating the clock signal uses crystals. While this method is well known and is reliable, off-chip generators take valuable circuit board space and have minimum height restrictions. A crystal-based system also requires extra pins for connecting the crystal to an integrated circuit requiring the clock signal. The crystal generator also requires external resistors and capacitors, adding cost, but more importantly takes more board space. Other disadvantages include an inability to operate over extended voltage ranges; long start times when power to the system is turned on; and high power consumption, making the systems less attractive in battery-powered applications.

On-chip oscillators have been designed for applications that demand low cost and low power consumption and applications that can't afford the space or pin requirement that crystal oscillators demand. For instance, ring oscillators have been used in IC designs where an exact clock signal is not required. Large performance variations, however, may be seen by the system as the ring oscillator frequency can vary over process differences, voltage variations and temperature excursions.

Yet another solution that designers have devised is to use of resistor-capacitor (RC) oscillator designs. RC oscillators lack the frequency accuracy of crystal oscillators, but are advantageous in that they can allow instant start-up of the clock signal from a stopped state. They also have low power consumption. However, when using analog electronic components such as those in the RC oscillator, it may be difficult to obtain precise voltages or measurements because analog components have many parameters that vary with process, temperature or power supply. For example, one or more reference voltages for an integrated circuit may be generated from a bandgap reference voltage circuit. If, however, the bandgap reference voltage is not accurate due to variations in power supply or temperature, then all reference voltages derived therefrom will also be inaccurate. This could induce substantial errors in the operation of the integrated circuit.

### SUMMARY

In one aspect, a self-calibrating integrated circuit includes a processor having at least one analog function used with the processor; one or more sensors adapted to sense one or more environmental parameters of the at least one analog function; and a solid state memory being configured to store the one or more environmental parameters of the at least one analog function.

Implementations of the above aspect may include one or more of the following. One analog function can be provided by an oscillator. The one or more environmental parameters includes temperature or supply voltage. The one or more sensors include one or more temperature sensors, which can

be diodes with metallization to screen out light. The one or more sensors include one or more hot-electron sensors, which can include deep well diodes. The one or more sensors include one or more hot electron generators such as ring oscillator-based hot electron generators. The one or more sensors include one or more heaters, which can include polysilicon resistors placed over a diode and transistors. The outputs of the sensors are provided to an analog switch. An analog to digital converter can be connected to the analog switch and to the processor to provide environmental data.

This type of A/D converter is typically included in mixed-signal systems already, so only a MUX is necessary for the autocalibrator. The A/D converter can be used at very low frequencies (since environmental factors like temperature do not change very fast) and it can be implemented with an inexpensive delta-sigma configuration.

Advantages of the invention may include one or more of the following. The system eliminates an external clock by using temperature compensated RC generator. The embedded FLASH memory holds self-calibration data. Each chip self calibrates during testing. Basically, the on-board ring oscillator is compared to a highly accurate crystal oscillator output during testing. The temperature is then varied using the on-chip polysilicon heater or a hot/cold chuck on the test system. Also, the voltage supply is varied to evaluate the impact of voltage on clock output. Additionally, the chip has temperature sensors at key locations across the chip. These sensors can be sensed using an on-chip A/D converter. The system minimizes wide variations in clock signal frequency over operating parameter variables such as voltage and temperature. The resulting ring oscillator is accurate for flash memory operation, requires less power, fewer pins and has fast start-stop gating. The system optimizes operating performance by dynamically monitoring environmental parameters and adjusting the operation and clock signal frequency. The system reduces cost by eliminating an external crystal clock. The system also frees up one or more pins that are normally dedicated to clock input signals. External precision components are not necessary since the FLASH memory calibrates the chip's mixed signal circuits to generate a precise, repeatable clock signal. The system maintains accurate clock signals over extended period since it has extensive self-test modes that allow it to self-calibrate.

The system achieves a low cost but sophisticated product which may be used in critical and precision applications that require calibration after manufacture of the individual functions of the system, and heretofore could only be implemented with more costly and space-consuming externally adjustable discrete components.

### BRIEF DESCRIPTION OF THE DRAWINGS

The accompanying drawings, which are incorporated in and form a part of this specification, illustrate embodiments of the invention and, together with the description, serve to explain the principles of the invention:

FIG. 1 shows an exemplary IC with self-calibration capability.

FIG. 2 shows an exemplary process for maintaining an oscillating frequency.

### DESCRIPTION

FIG. 1 shows an exemplary IC 10 with a digital portion 20 and an analog portion 40. The digital portion 20 includes a processor 12 and memory array 14, among others. The memory array 14 can be static random access memory

(SRAM), dynamic random access memory (DRAM), and a FLASH memory, among others. The analog portion 40 also includes an on-chip clock oscillator 42 and one or more analog circuits 44 such as radio frequency (RF) transceivers or optical transceivers, for example.

The on-chip clock oscillator 42 can be a ring-oscillator or an RC oscillator or an LC oscillator. Typically, as known in the art, a ring oscillator includes a series of discrete components including transistors, capacitors, among others. For example, as discussed in U.S. Pat. No. 6,211,744 to Shin and U.S. Pat. No. 6,154,099 to Suzuki, et al., a conventional ring oscillator can be formed by connecting an odd number of inverters in a ring shape. In such a configuration, if Y is the state (signal level) at a connection point, the Y signal is inverted to Y by the next-stage inverter, and the Y is further inverted to Y by the second next-stage inverter. The signal level is sequentially inverted, and becomes Y at the connection point through one round because an odd number of inverters are connected. Through one more round, the signal level becomes the original Y. In this manner, the ring oscillator self-oscillates. An oscillation output is obtained from the output node of an arbitrary inverter.

Another conventional ring oscillator can use a NAND gate circuit for controlling start/stop of oscillation is inserted in a ring formed by connecting a plurality of even number of inverters. The start/stop of oscillation is controlled by externally inputting an "H"- or "L"-level control signal CNT to the NAND gate circuit. That is, the control signal CNT is first set at "L" level and then changed to "H" level to start oscillation. When the control signal CNT is at "L" level, an output signal from the NAND gate circuit is fixed at "H" level. Outputs from the odd-numbered inverters change to "L" level, outputs from the even-numbered inverters change to "H" level, and the initial states of the output levels of the respective inverters are determined. In this state, the ring oscillator does not oscillate. When the control signal CNT changes to "H" level, the NAND gate circuit substantially operates as an inverter, and the ring oscillator oscillates in the above manner where an odd number of inverters are connected in a ring shape.

The frequency of the oscillation signal from the conventional ring oscillator depends on the number of stages of inverters and a wiring delay. Hence, the lower oscillation frequency is obtained by increasing the number of stages of inverters and the length of the signal line. This increases the circuit size. Further, although the voltage-controlled oscillators have an identical circuit configuration, they have different oscillation frequencies due to certain factors of the production process. For example, the process can affect the gate delay time that can affect the precision of the oscillator.

The RC oscillator allows quicker oscillation time. A number of conventional RC oscillators can be used. For example, as discussed in U.S. Pat. No. 5,739,728, an RC oscillator has a capacitor C1, first and second resistors R1 and R2, a comparator COMP and a switch S1. When the voltage across the capacitor C1 is less than a bias voltage, the output of the comparator is at a logic low level and switch S1 is open. The capacitor is charged by current flowing through resistor R1 from a voltage source. When the voltage across the capacitor exceeds bias voltage, the output of the comparator switches to a high logic level which closes switch S1. The capacitor is then discharged through resistor R2. When the capacitor voltage drops back below the bias voltage, the comparator opens switch S1, thereby beginning a new cycle. As with the ring oscillator, the RC oscillator also faces frequency drift caused by process, temperature and voltage variations.

To capture information that allows the processor 12 to automatically calibrate the IC 10 so that the on-chip clock oscillator 42 is precise and accurate in spite of process, temperature or power supply variations, various sensors 46-48 are placed at predetermined locations in the IC 10 to sense environmental variations.

The analog portion 40 includes one or more temperature sensors 46, which can be diodes with metallization to screen out light. The output from the temperature sensors 46 are eventually digitized and provided to the processor 12 for adjusting the IC 10. To calibrate the temperature sensors 46, the analog portion 40 also has one or more heaters 52, which can be polysilicon resistors placed over a diode and transistors. The heaters 52 can also be used to bring the IC 10 to a predetermined temperature range if the IC 10 is below its normal operating temperature.

The analog portion 40 also includes one or more hot-electron sensors 48, which can be deep well diodes. The term hot-electron effect refers to the phenomenon of electrons which originate from FET surface channel currents, from impact ionization currents at the FET drain junction, or from substrate leakage currents. Electrons drifting from the gate may gain sufficient energy to enter into the gate, or they may collide with the silicon atoms and generate electron-hole pairs. The hole adds to substrate current, and the secondary electron may be injected into the gate of a subsequent FET. The deep well diodes sense the hot electron effect and provide this information eventually to the processor 12 to automatically compensate for hot electron effects. To provide calibration data for hot electron characterization of the IC 10, the analog portion 40 also includes one or more hot electron generators 50 such as small ring oscillators.

The outputs of the sensors 46-48 are provided to analog switch 53 that in turn is connected to a precision analog to digital converter 54 (ADC). The analog switch 53 is controlled by the processor 12 to select the output of one of the sensors 46-52 to the input of the ADC 54 to digitize autocalibration data. In one implementation, the ADC is a 12 bit ADC. The output of the ADC 54 is provided to the processor 12 to make decisions and the flash memory in the memory array 14 to store the autocalibration data.

The processor 12 can check the temperature at different locations on the IC 10 and average the temperature being sensed to better adjust to the actual temperature present. By monitoring the temperature of the IC 10, the processor 12 can detect whether the oscillator 42 is deviating from its specified frequency. In one embodiment, the flash memory has a parameter array with one element storing the operating temperature of the IC 10. The operating temperature information is used to generate differing delays based on circuit characteristics and based on temperature-induced shifts in oscillator frequency. The processor 12 adjusts the timing when the temperature changes outside the nominal setting by changing the number of the delay stages to compensate for the temperature range variations.

In addition to the temperature adjustments made by the controller, the system can also detect the supply voltage that the system is presently operating at and adjust for variations in the supply voltage. Like the temperature, the voltage represents an offset from the nominal voltage setting. If the operating voltage is not at a nominal value, the controller adjusts the ring oscillator delay path to compensate for the voltage differential. Environmental parameters of the IC 10 include temperature, supply voltage and other external parameters which effect the performance of the IC 10.

## 5

Additional details on the device that corrects temperature and voltage variations are discussed in a co-pending patent application entitled "Ring Oscillator Dynamic Adjustments for Auto-calibration" and having Ser. No. 09/930,822, the content of which is hereby incorporated by reference.

An exemplary process of calibrating and correcting the IC **10** is shown in the flow chart **200** of FIG. **2**. First, the IC **10** is initialized (step **201**). The process **200** checks for user adjustments (step **202**). If a user wants to adjust the operating frequency of the clock to meet the temperature and voltage conditions of the application, the process **200** adds the adjustments so that the oscillator moves toward the user specified operating frequency.

Next, in step **203**, voltage, hot electron and temperature calibration signals are sent to the voltage generators, hot electron sources and heaters, respectively. These calibration signals are preferably generated by the processor **12** of FIG. **1** so that they have a known level and can be swept over a known test range. In process step **204**, the hot electron sensor responses are monitored. In decision step **206**, the hot electron sensor responses are averaged and the averaged result is compared to a predetermined range. If the response is out of range, it is corrected in process step **208**. The above steps are performed for each sensor type. For example, in step **210**, the temperature sensors are monitored. In decision step **216**, the temperature responses are averaged and the averaged result is compared to a predetermined range. If the response is out of range, it is corrected in process step **218**. Next, in step **220**, the voltage sensors are monitored. In decision step **226**, the voltage responses are averaged and the averaged result is compared to a predetermined range. If the response is out of range, it is corrected in process step **228**. In the above manner, each sensor type is monitored and the environment sensed by the sensor type is adjusted. For example, if the temperature gets hotter (indicating slower silicon and slower ring oscillator) the flash system will move the oscillator settings to the faster settings to compensate for the slow down because of increased temperature or a corresponding decrease in operating voltage.

The data is continually collected. This is done by having the processor **12** instruct the switch **53** to connect to each sensor **46-52** in seriatim and the ADC **54** to digitize the environmental parameters, and the FLASH memory file to store the output of the ADC **54** (step **240**). The FLASH memory file can store one sample point for each sensor, or can store historical data for the sensors.

To keep a constant clock frequency, the process **200** moves the oscillator as to the environmental changes. Moreover, the processor **12** can predict the environmental changes based on historical data.

Additionally, the process can calibrate sub-systems. For example, with respect to the wireless transceiver, responses that can be calibrated and corrected in with calibration signals from the processor **12** can include transmit/receive gain over temperature, transmit/receive gain over voltage, transmit/receive gain over hot electron effect, and frequency responses of the PLL's voltage-controlled oscillator and frequency steps of a phased-lock loop as function of voltage, temperature and hot electron level, for example. This process of calibration and correction can be conducted for each sub-system of the IC **10**.

## 6

The term "FLASH memory" is used above to generally describe any non-volatile technology. The present invention applies to all non-volatile floating gate technologies such as EEPROM and FLASH memory. Additionally, RAM storage where the contents of the RAM are maintained for an extended period (more than 1 year) by an external battery source would also be within the scope contemplated by the present invention as well as any method of memory that is erasable and electrically programmable.

Moreover, although a self-calibrated clock has been discussed above, other self-calibrated functions are contemplated and within the scope of the invention. These functions include: analog-to-digital converter, digital-to-analog converter, voltage reference, current reference, timer, amplifier having a calibrated frequency response (high or low pass filter), offset voltage adjustment, bandpass filter (frequency detection), television or radio tuner, temperature transducer amplifier (linear and non-linear temperature profiles), pressure transducer amplifier, analog multiplier and divider, among others.

Although specific embodiments of the present invention have been illustrated in the accompanying drawings and described in the foregoing detailed description, it will be understood that the invention is not limited to the particular embodiments described herein, but is capable of numerous rearrangements, modifications, and substitutions without departing from the scope of the invention. The following claims are intended to encompass all such modifications.

What is claimed is:

1. An integrated circuit, comprising:

a processor having at least one analog function used with the processor;

a radio frequency circuit coupled to the processor;

one or more sensors adapted to sense one or more environmental parameters of the at least one analog function; and

a solid state memory being configured to store the one or more environmental parameters of the at least one analog function.

2. The integrated circuit of claim 1, wherein said at least one analog function is an oscillator.

3. The integrated circuit of claim 1, wherein the one or more environmental parameters includes temperature or supply voltage.

4. The integrated circuit of claim 1, wherein the one or more sensors include one or more temperature sensors.

5. The integrated circuit of claim 1, wherein the one or more sensors include diodes with metallization to screen out leakage-causing light.

6. The integrated circuit of claim 1, wherein the one or more sensors include one or more hot-electron sensors.

7. The integrated circuit of claim 1, wherein the one or more sensors include deep well diodes.

8. The integrated circuit of claim 1, wherein the one or more sensors include one or more hot electron generators.

9. The integrated circuit of claim 1, wherein the one or more sensors include ring oscillator-based hot electron generators.

10. The integrated circuit of claim 1, wherein the one or more sensors include one or more heaters.

11. The integrated circuit of claim 1, wherein the one or more sensors include polysilicon resistor heater placed over a diode and transistors.

12. The integrated circuit of claim 1, wherein the outputs of the sensors are provided to an analog switch.

7

13. The integrated circuit of claim 1, further comprising an analog to digital converter (ADC) coupled to the processor.

14. The integrated circuit of claim 13, wherein the ADC is shared with an on-chip mixed-signal circuit.

15. The integrated circuit of claim 13, further comprising a multiplexor coupled to the ADC to share the ADC with autocalibration functions.

16. The integrated circuit of claim 13, wherein the ADC operates at a low frequency.

17. The integrated circuit of claim 13, wherein the ADC comprises a delta-sigma ADC.

18. An integrated circuit, comprising:

a processor;

a radio frequency circuit coupled to the processor;

8

an oscillator coupled to the processor and the radio frequency circuit, the oscillator having a frequency varied by one or more environmental parameters;

one or more sensors adapted to sense one or more environmental parameters; and

a solid state memory being configured to store the one or more environmental parameters of the at least one analog function.

19. The integrated circuit of claim 18, wherein the one or more environmental parameters includes temperature or supply voltage.

20. The integrated circuit of claim 18, wherein the one or more sensors include one or more temperature sensors.

\* \* \* \* \*